

Ford Focus 1.6-litre Duratorq TDCi with Durashift CVT

Better fuel economy, increased comfort, choice of continuously variable or virtual seven-speed modes

A car with excellent power transmission behaviour should be like a pleasant home or a nice easy chair. If you just get in it and feel good right away, then the quality is right.

One of the reasons why getting in and driving the Ford Focus range feels so good is because of the incredible adaptability of its all-new Continuously Variable Transmission (CVT). Anyone wishing to enjoy the safety, convenience and economy of this vehicle doesn't need any special skills, though. The CVT in Focus and Focus C-MAX is controlled by a shifter in the centre console, using the standard shifting pattern to which most drivers are accustomed. The powerful, 109-hp Duratorq TDCi diesel engine combined with the new CVT transmission, jointly developed by Ford and the transmission experts from ZF, provide quick, refined driving dynamics as well as good fuel economy.

A transmission's most significant characteristic is the so-called 'spread' of its gear ratios. The spread is the relationship between the transmission's longest and shortest gear ratios. Back in the days when four-speed gearboxes were standard, a factor of 4.0 was considered good, while engineers nowadays are striving for a spread factor of 5.0. The new CVT from Ford and ZF achieves a factor of 6.0, a breakthrough in transmission technology putting everything that has come before it in the shade.

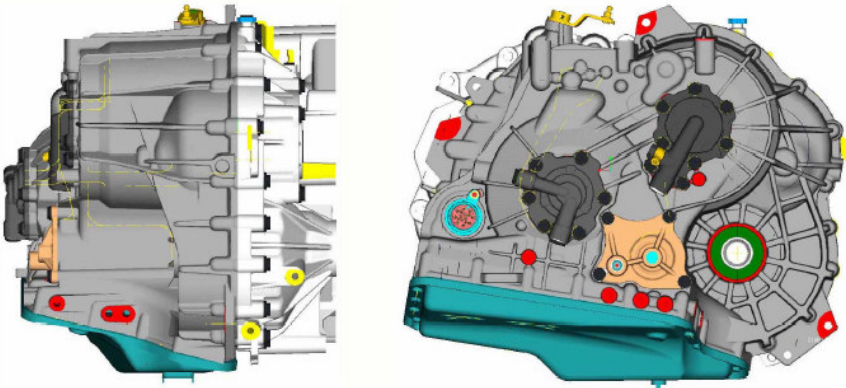

The Ford-ZF CVT in the Focus range is a compact, lightweight unit with a shaft distance of 16.5 cm and a total weight, including the converter and differential, of only 86 kg.

Instantaneous gear changes are the second major feature of the Durashift CVT. With a strong depression of the accelerator pedal, prompting kick-down, the system immediately downshifts in a continuously variable mode. This occurs without the slightest shifting delay, since no gears need to be engaged or synchronised. All that is needed inside the gearbox is a swift adjustment of the bevel gears, activated instantaneously by a special radial piston oil pump.



On the drive side, the Durashift CVT transmission is equipped with a hydraulic torque converter, which, however is consequently bypassed by a clutch starting at very low engine speeds already.

To understand this novel and fascinating approach to power transmission, it is necessary to take an in-depth look at this technology. In some respects it does function along the lines of conventional systems, but it combines certain characteristics in new ways, opening the door to new possibilities. The hydrodynamic torque converter, which compensates for drive slip, has been taken from a conventional automatic transmission. Ford Focus range uses a compact, yet stiff, converter, fitted with a torque converter lockup clutch, which eliminates converter slip at higher engine and vehicle speeds for better fuel economy. A simple planetary gear set with two hydraulic clutches, which may be actuated under load as well, is used for changing between forward and reverse.

For the driver, the Ford Durashift CVT feels very similar to a conventional five-speed automatic transmission. In the automatic mode, the Durashift CVT thankfully avoids the typical sound of earlier generations of continuously variable transmissions: a mixture of a vacuum cleaner and an aircraft turbine. These acoustics failed to provide the driver with reliable feedback about acceleration and vehicle speed, and were generally rejected by consumers.

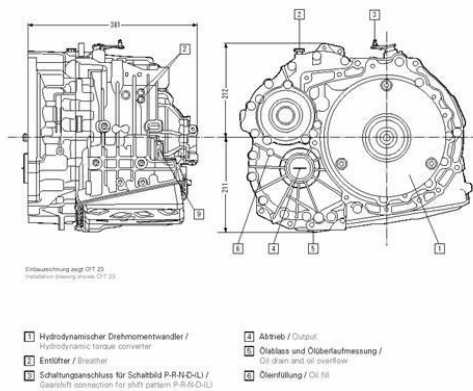

The Ford Durashift CVT's housing is a mere 381 millimetres long, making it ideal for use in front wheel drive vehicles.



The Ford Durashift CVT avoids this acoustic trap altogether. In the automatic mode, it has been programmed to vary the gear ratios in a logical progression. It sounds and behaves very much like a state-of-the-art five-speed automatic transmission with exceptionally well-balanced shifting programmes and clutches - and that is exactly how it works in practice.

Gearbox Principles:

One of the elementary laws of automotive engineering is that transmissions with a higher number of gear ratios improve a car's fuel economy. While in the early days three manually shifted gears were sufficient to move a vehicle at a top speed of 80 km/h, they were replaced by four-speed manual gearboxes about fifty years ago, and five-speed manual gearboxes became more or less standard about ten years ago. These allow even small cars to reach speeds of circa 170 km/h, with fuel economy between five to seven litres per 100 kilometres.

The automatic transmissions used in automotive engineering have followed the trend from three- to four- or five-speed systems within roughly the same period of time. While geared automatic transmissions usually have one ratio less than manual gearboxes, they provide convenience, requiring the driver to operate only two instead of three pedals. With regard to fuel economy and driving dynamics, however, they often lag behind manual units, since one less gear reduces the transmission's potential to exploit the entire spectrum of engine speeds available. This inevitably reduces either dynamic performance or fuel economy. The flexibility of modern gearboxes is especially put to the test by state-of-the-art diesel engines. Their tendency to develop sudden and massive torque at roughly 1,700 rpm, opening up a narrow window of usable engine speed which already finishes at no more than 4,300 rpm, presents special challenges for transmission engineers. Ford's answer to these challenges is to be found in the new Focus, equipped with the 1.6-litre TDCi diesel engine and the brand-new Durashift CVT.

Special Aspects of CVT Technology

The new Ford Durashift CVT, developed jointly by Ford engineers and transmission experts from ZF, sets new performance benchmarks: The driver can choose between an automatic mode with seamless, virtual gear changes and a seven-speed select-shift mode. It also performs as a continuously variable transmission across a wide range of situations.

All of these features are spearheading a new era of power transmission technology, enabling new records to be achieved in terms of driving dynamics. At the same time, this technology offers new convenience and comfort without compromising fuel economy. Of course, not all of these factors can come into play simultaneously, but each of these new, optimised features has a firmly defined area of application.

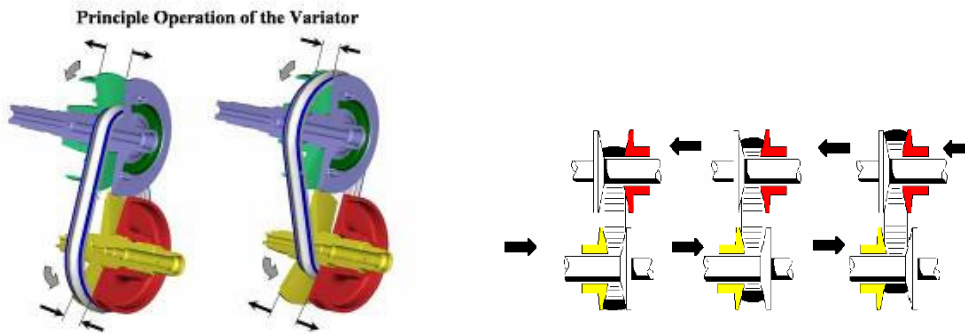

The thrust link belt in Durashift CVT enables seamless selection of gear ratios. The belt and its thrust links are made from high-alloyed maraging steel, originally developed for applications in aerospace technology.

Drivers simply select their preferred driving mode – automatic or select-shift – by touching the gear shift lever or pushing down the accelerator pedal. The Ford Durashift CVT does the rest.

Following the functional example of mountain bikes

Modern mountain or trekking bikes bear witness to the fact that developments in the area of transmission technology have entered a new era. 24 or 28 gear transmission systems are just enough when it comes to taking feeble human power and using it to conquer difficult and complex mountain paths.

Every bicyclist will tell you that a higher number of gears generally helps applying limited available propulsion power on difficult terrain. They help save energy and improve performance.

Ford's new-generation CVT transmissions are essentially based on the same principle and objectives. And while the 109-hp Ford Focus CVT, developing 240 Newton metres of torque, is certainly a robust platform, the goal remains to optimise driving dynamics and fuel economy. Ford's latest developments are leading the way.

The Durashift CVT uses a steel thrust link belt, instead of gears. This belt construction more or less follows the same principle as a bicycle's gears. Since it can adapt seamlessly to the engine speed, it theoretically provides an infinite number of 'gears.' An infinite number of gear ratios, however, makes the engine sound somewhat like a vacuum cleaner. Many drivers feel that this is neither a suitable sound pattern for an automobile, nor does it provide appropriate performance feedback. That is why, in practice, the Ford-ZF unit selects optimum performance characteristics from the infinite number of possible transmission speeds. According to conventional wisdom, five or seven are enough to operate a modern car comfortably and provide good fuel economy. The crucial issue is the spread of the ratios. The Durashift CVT, as previously mentioned, has a factor of 6.0. A simple movement is all it takes to switch the Focus range from the automatic to the select-shift mode. Yet this movement is writing a new chapter in automotive engineering history.

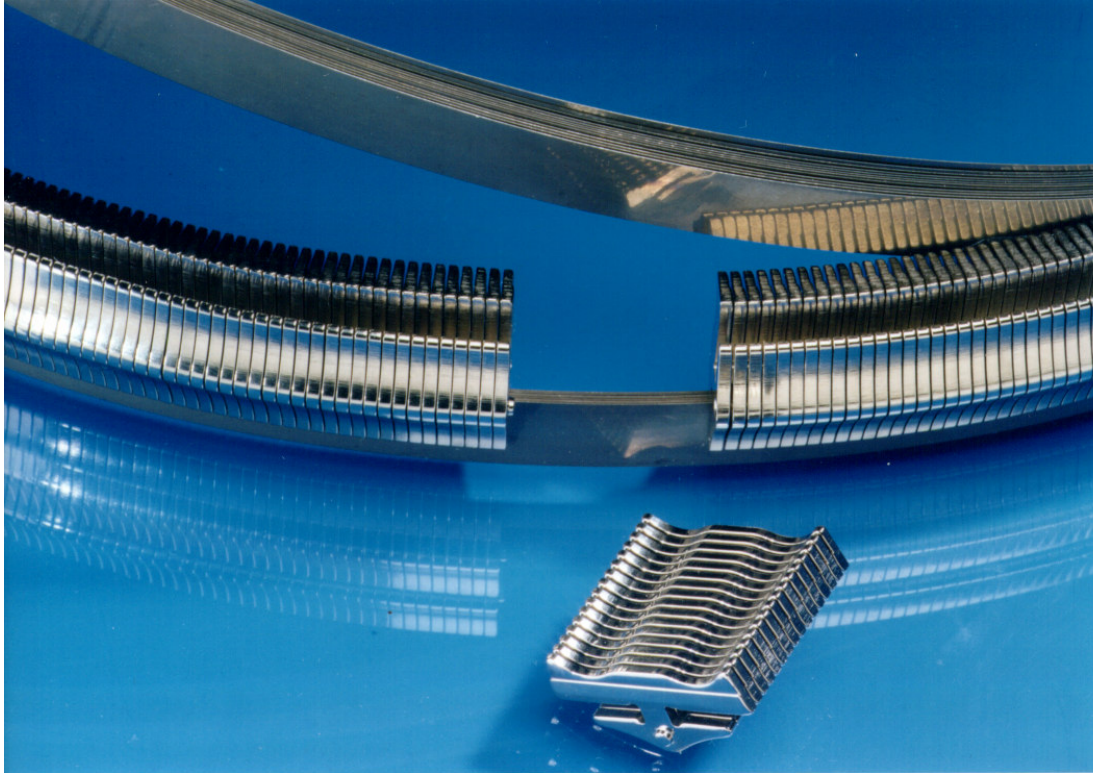

The Van Doorne thrust link belt, shown here partially disassembled, consists of 400 links and two lines of steel belts with 12 rings each.

Automatic Mode:

In the automatic mode, Durashift CVT operates at higher levels of precision than conventional automatic transmissions. The hydrodynamic torque converter is capable of amplifying the engine's starting torque by a factor of 2,1 : 1. The transmission control system operates in the automatic mode. The converter clutch locks as soon as possible after the vehicle is in motion, often at speeds as low as 20 km/h, largely avoiding any increase in fuel consumption caused by the slip of the hydrodynamic converter.

The transmission control system has been programmed for optimum fuel economy, reducing engine speed within the defined pattern of gear ratios. The spread of gear ratios used is 6.0, that is, the highest gear is exactly six times longer than the lowest.

The carefully programmed transmission control unit maps enable swift downshifting for dynamic acceleration. Several overlapping programme maps use signals from motion sensors in the accelerator pedal. The fast-off mode and corner detection by ABS wheel speed sensors prevent inappropriate upshifting, for example prior to cornering or after an aborted attempt to overtake.



Durashift CVT transmission's gearshift lever can be set for fully automatic selection of the transmission ratios or in the so called select-shift mode when placed in the right-hand shifting slot.

In the **kick-down mode** Durashift CVT will optimise dynamics for acceleration. Only in this case (at over 95 percent of full engine load), the transmission will be operating in the continuously variable mode, seamlessly varying the gear ratios to keeping the engine running at peak power at 4,000 rpm. This achieves optimum acceleration, while overtaking for example. The slightest release of the accelerator pedal (reducing engine load below 95 percent) will cause the transmission to return to its normal automatically selected ratio mode.

In the **select-shift mode**, as in the automatic mode, Durashift CVT offers seven ratios, spread by a factor of 6.0 : 1. The driver selects these by simply moving the gearshift lever (forward for downshifting, backward for upshifting). Experienced drivers will find this mode very useful for adjusting their cornering speed, particularly on winding mountain roads, or while accelerating. The select-shift mode can be helpful, as well, while going downhill or when towing another vehicle. Should the driver forget to downshift properly – during sudden stops for example – the transmission control unit will do so automatically. However, to accelerate again, the driver must change gears.

The **cold start mode** offers special advantages to the driver. On slippery roads or in urban traffic, it enables the driver to start in second gear. This tells the hydraulic torque converter to apply the engine's torque to the wheels with care, to avoid spinning the driving wheels.

Another special characteristic of the Durashift CVT comes into play in extremely cold conditions. At very low oil temperatures the hydraulic shifting signals for the transmission control unit would function harshly. To counter this, at oil temperatures below ten degrees centigrade the lockup clutch of the torque converter is kept in the unlocked position. This causes the oil to heat up rapidly and improve performance. Once the oil has reached ten degrees centigrade the converter clutch will lock as usual. This transition is carried out gradually, avoiding and sudden jolts or changes in performance are avoided.

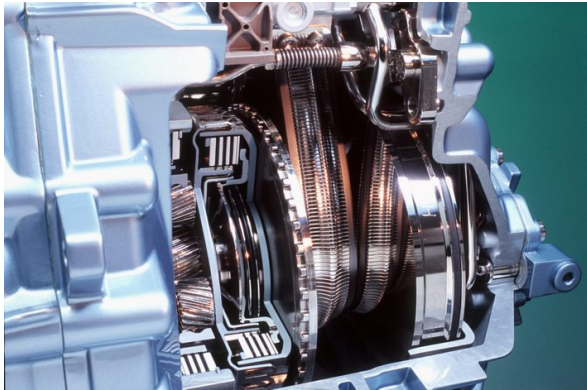

The planetary gear set responsible for switching between forward and reverse gears is situated on the primary shaft of the Durashift CVT transmission (left), next to it the gear change clutch for the forward-rearward-shifting only and - more to the right - the pair of conical drive wheels for driving the power belt.

Shifting Strategies

The control system of Durashift CVT uses several overlapping shifting and clutching strategies. During the design and development process, these have been subjected to continuous refinement to assure their smooth interaction within the transmission system. Drivers need not understand the multitude of overlapping functions. The seamless integration of the system as a whole allows the driver to 'sit back and relax.' The following brief summary of the various interacting functions in the Durashift CVT is provided for completeness' sake.

Open Clutch at Standstill and Engine Idle

At standstill and idle – shifting lever in position D or R – the clutches of the planetary gearbox are in the open position, applying low torque to the entire powertrain. This allows the engine to idle at a particularly low speed, thus improving fuel economy.

Forward

When the vehicle is moving forward, the clutch in the planetary gearbox is in the locked position, keeping the planet carrier firmly connected to the drive variator. The planet gear set does not reduce the gear ratio, but rotates in this fixed position without being subjected to wear.

Reverse

In reverse, the clutch in the planetary gearbox is positioned to connect the internal gear and the gearbox housing. Power is transmitted to the variator via the sun wheel of the planetary gearbox.

Fast-off Detection

A quick release of the accelerator pedal requires different driving signals than a slow release of the pedal. The fast-off mode typically comes into play when the driver slows down prior to cornering or aborts an overtaking attempt. In such cases, upshifting would be counterproductive: the engine's braking power is needed. The fast-off mode therefore prevents the transmission from upshifting. Depending on driving style and dynamic resistance (uphill/downhill detection), engine speed will be reduced more or less rapidly.

Sport Mode

Once the transmission's adaptive electronics have recognised that the driver prefers a sporty style of driving, engine speed will be maintained at a higher level to increase braking power. Following a return to a cruising speed or slower driving, the adaptive system will immediately shift back to a lower, fuel-saving engine speed.



Downhill Detection

Downhill driving is detected by the system correlating the accelerator pedal position and speedometer signals. If all systems indicate that the vehicle is moving downhill, engine speed will be increased to assist braking when the driver takes the foot off the accelerator pedal. To accomplish this, the current ratio of the variator is maintained without upshifting. If this is insufficient and the vehicle continues to accelerate, the system will automatically downshift to make more effective use of the engine's braking effect. This strategy helps to save the brakes and maintain the highest levels of traffic safety.

Corner Detection

The constant comparison of rear wheel speeds within the ABS system provides accurate cornering information at all times. Depending on the radius of the turn, the transmission will avoid upshifting in order to give the driver a more direct feeling as the vehicle proceeds through the corner. Undesirable upshifting immediately before a corner is prevented by the fast-off mode, even while the vehicle is still moving forward in a straight line.



In contrast to conventional transmissions, the Durashift CVT transmission uses a thrust link belt - and instead of a shift mechanism two sets of conical drive gears.

Automatic Mode

With the lever in the automatic position, gear ratio and engine speed are controlled by programme maps. In order to achieve optimum fuel economy at cruising speed, engine speed will be reduced within certain logical parameters and the vehicle operated in the highest possible gear. Downshifting signals are prompted by both the travel of the accelerator pedal and the speed at which the pedal is depressed. When the pedal is depressed completely, activating the kick-down mode, the transmission will automatically shift to a gear ratio allowing the engine to run within close proximity of its nominal speed of 4,000 rpm. This achieves maximum acceleration dynamics. As long as the kick-down mode is in effect, the transmission will continue to operate in a continuously variable mode, without simulating gear ratios, to provide optimum acceleration while overtaking, for example.



Select-Shift Mode

After moving the gearshift lever to the right-hand gate, the transmission will obey the shifting commands of the driver. The control module has a programme with seven fixed transmission stages, converting the automatic transmission into a virtual, manually shifted seven-speed transmission. When changing to the select-shift mode, the respective gear ratio used at that time is maintained and considered in the subsequent gear change. As a result the first gear change may turn out somewhat larger or smaller than usual.

In the select-shift mode, as well, kick-down can be used for downshifting without moving the stick as soon as the engine operates under more than 95 percent load. In addition, the Durashift CVT will automatically upshift once the engine has reached its maximum permissible speed. However, if the engine peaks in a manually selected gear without a kick-down signal being given at 95 percent load, the transmission will retain the selected gear and not shift into a higher one.

When downshifting in the select-shift mode, the transmission will automatically prevent the engine from over-revving by projecting the shifting speed. Likewise, the transmission will automatically prevent stalling as a result of insufficient engine speed.

In winter, the select-shift mode allows the vehicle to be started in second gear providing gentle application of starting torque.

Hydraulic Emergency Mode

Should the transmission control system detect any serious transmission problems, it automatically switches to a hydraulic emergency mode. Once this has happened, shifting is accompanied by stronger jolts and only a limited number of gear ratios are available.

Mechatronics – modern control technology, made as simple as possible

In an extremely small space, Durashift CVT accommodates highly complex, high-precision transmission control technology. This is the first design concept to deliberately avoid any resemblance to conventional five-speed automatic transmissions. Their level of complexity, including several housings for electronic and hydraulic control systems and associated cables and wiring, no longer seems appropriate for this day and age.

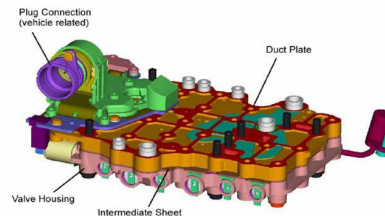
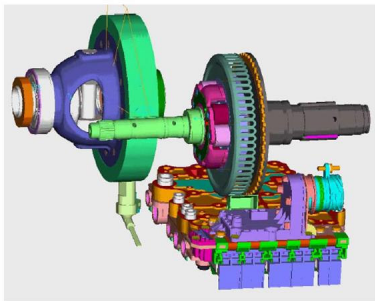

The mechatronic module of the Durashift CVT packages all the control technology in a single control block. Also, there is no wiring harness inside the gearbox.



The number of sensors and control modules used by Durashift CVT has been reduced to an absolute minimum and all the components have been packaged into such a tight space that, in the end, only a single mechatronic module is installed underneath the actual gearbox. This unit has no external cable harnesses, sensor connections or control modules. Rather, it combines all of these elements in a single mechatronic package, which handles all transmission control functions. This single unit accommodates the printed circuit for the electrical switching elements and processors as well as the hydraulic valves and relays in an extremely tight space. The module is located between the gearbox and oil sump and protected from dirt, grime and wear. External sensors are limited to those connected to the engine control unit for obtaining quick and reliable signals about accelerator pedal position and movement.

The mechatronic module thus replaces conventional transmission control technology which normally occupies several control module housings and includes multiple sensor populations. In addition, the CVT mechatronics precisely measure the relatively high volumes of hydraulic oil flow required for accurate and virtually instantaneous actuation and control of the conical variator discs. Oil is supplied to the entire system by a seven piston radial pump, which has been designed to provide the precise oil flow and pressure characteristics needed by the system.

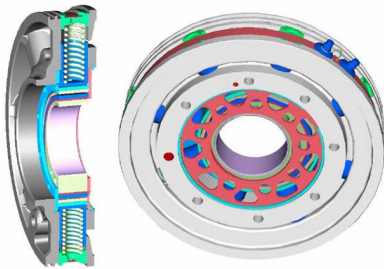

The oil flow and pressure build-up of the radial piston pump have been custom tailored to the hydraulic supply requirements of the Ford Durashift CVT.

Ford Durashift CVT's Optimised Fuel Economy

There is, however, one difference between conventional automatic transmissions using torque converters and Durashift CVT: Durashift CVT's fuel economy nearly matches that of a manual gearbox. Hydraulic converter losses are avoided by mechanically locking the start-up clutch at extremely low speeds, in many driving situations as low as 20 km/h. At all higher speeds Durashift CVT delivers nearly the same level of efficiency as a mechanical gearbox.

The CVT's ability to slightly improve the efficiency of power transmission at a given driving speed contributes to a remarkable difference in ECE fuel consumption ratings. At first glance, the overall efficiency of the new transmission appears in an unfavourable light. ECE fuel consumption with the CVT transmission versus a mechanical gearbox is markedly higher. This, however, applies only to the constant stop-and-go and low average speeds of urban driving. In city traffic a car often spends more time at rest than moving forward, and under these conditions Durashift CVT's fuel economy is comparable to conventional five-speed automatic transmissions.



Once the torque converter and the mechanical efficiency of the CVT belt drive help to improve fuel economy at higher vehicle speeds, the picture is entirely different. The faster a Focus fitted with Durashift CVT is being driven, the more favourably its fuel economy compares with that of a mechanical gearbox.

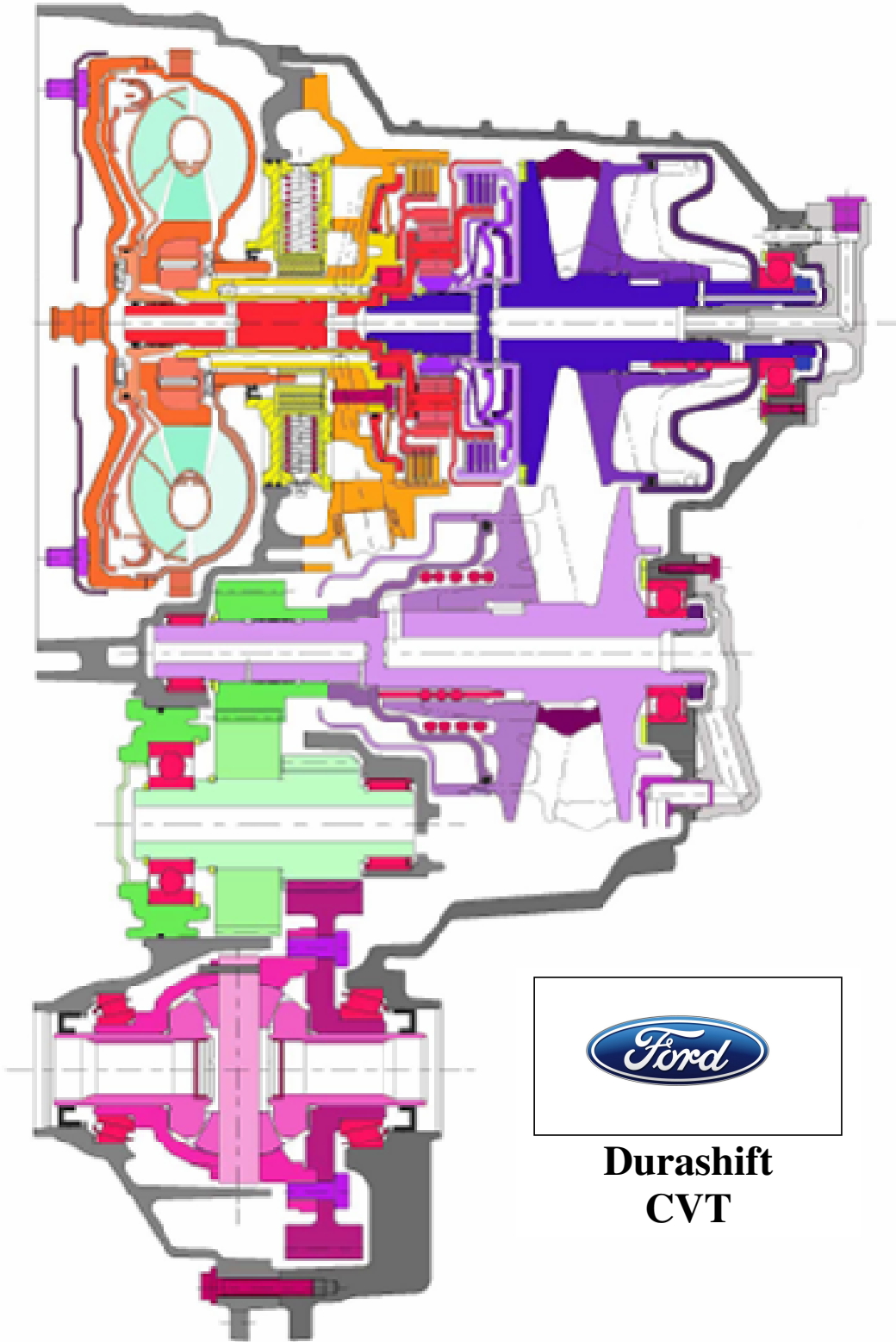

**Durashift
CVT**



Ford Durashift CVT technical specifications:

Designation:

Automatic transmission for front-wheel drive passenger vehicles, optional operation in continuously variable mode or select-shift mode with seven virtual transmission stages

Performance characteristics:

Maximum torque	240 Nm at n = 3,900 min ⁻¹
Maximum output	120 kW at n = 6,000 min ⁻¹
Engine speed range	750 rpm ⁻¹ – 6,500 rpm ⁻¹
Maximum converter torque forward	360 Nm*
Maximum converter torque reverse	360 Nm*

*limited stall torque

Dimensions:

Axle distance, engine - differential	206.7mm
--------------------------------------	---------

Oil pump:

Radial piston pump V _{geo}	17 cm ³
V _{max}	28 l/min

**Torque converter:**

Type W 235 S-WK with integrated lockup clutch and torsion damper

Tp2000 characteristic [Nm]: 136

Transmission belt:

Thrust link belt, type: VDT 30/12/1.8

Variator:

Shortest ratio 0.423

Longest ratio 2.52

Spread 6.0

Output ratio to intermediate shaft 1.593

Intermediate shaft ratio to differential 2.720

Differential final drive ratio: 4.33

Gear ratios in select-shift mode

1st 2.52

2nd 1.73

3rd 1.3

4th 1.0

5th 0.79

6th 0.63

7th 0.42

Differential:

Type: bevel differential

Size: bearing diameter of rolls 89mm

Gearing: bevel gear diameter 26.22mm, 34 teeth

Shifting pattern: P R N D + -

Control unit

Electro-hydraulic

Adaptive driving mode, diagnostics capability

Weights:

Gearbox: 65.2kg

Converter: 11.3kg

Oil: 6.0kg

Total weight: 82.5 kg

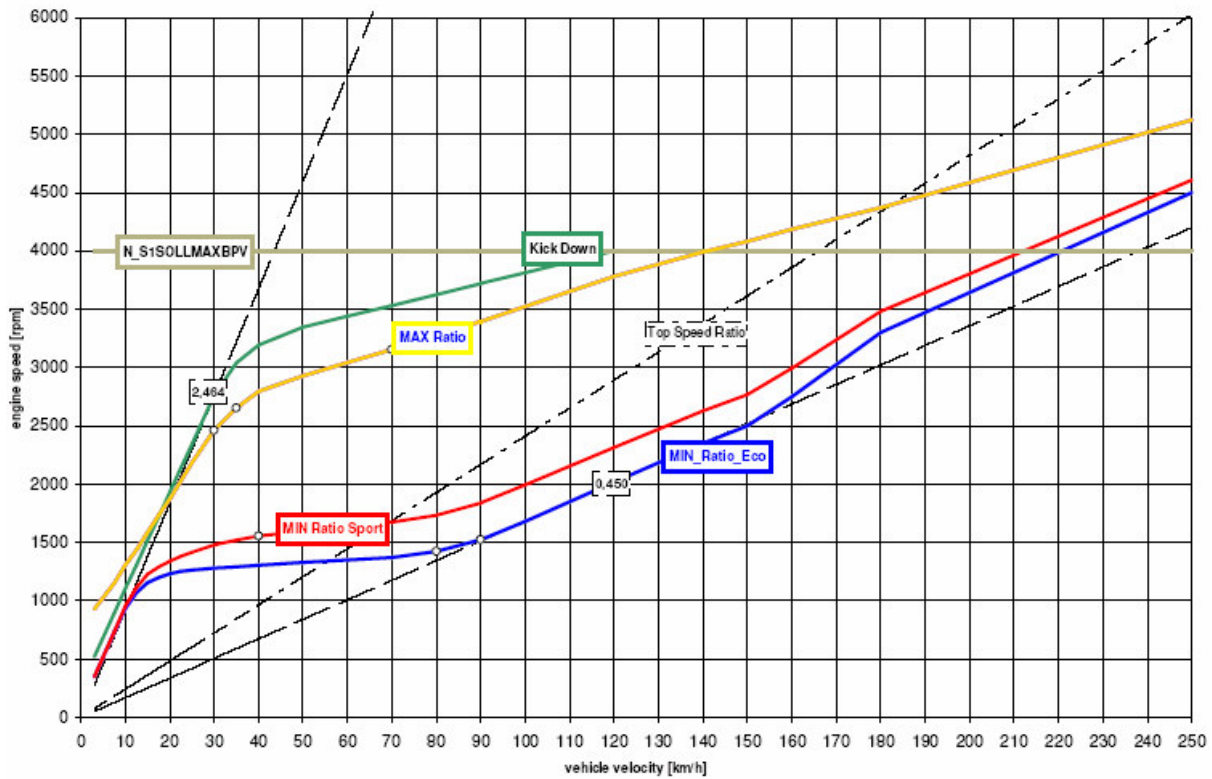

Basic Shift Schedule Ford Durashift CVT

###

Voor meer informatie kunt u contact opnemen met:

Jo Declercq
Tel: +32 3 821 21 03
Fax: +32 3 821 21 07
jdecler2@ford.com